



Platform, Youth and Caster Bed Assembly Instructions

Use for models: 4099,4499,4599,4100,4400,4500,4101,4401 and 4501 as well as the extra-long versions of these beds – identified with a Q added to the model number.

Tools required: $\frac{9}{16}$ " socket or wrench, #2 Robertson or Phillips screwdriver

Please read the instructions completely prior to starting.

Contents:

- A. 2 – Bed ends
- B. 8 – 4" Lag bolts
- C. 2 – Side rails
- D. 8 – Washers
- E. 4 – Slats
- F. 4 – 1 ½" Wood screws
- G. 4 – 1 ¼" Wood screws
- H. Posture board

4101, 4401 and 4501 models include casters and require a hammer for assembly.

1. Turn bed ends upside down.
2. Insert caster sleeves into $\frac{3}{8}$ " hole.
3. Hammer the sleeve lightly into the wood.
4. Insert the caster.

Please read instructions completely prior to starting.

1. Fasten the 2 side rails "C" to the 2 bed ends "A" using 8 – 4" lag bolts "B" with the 8 washers "D". Be sure grooves on side rails are on the inside, close to the bottom and the grooves for the guard rail "H" are facing each other on the inside of the bed ends.
2. Slide 4 slats "E" into the side rails. 2 slats are placed $\frac{1}{2}$ " from the bed ends & secured with a wood screw "G" at each end of the slat. Position the other 2 slats evenly spaced between the end slats. Secure the centre slats with one 1 ½" wood screw "F" at each end of the slat.
3. Posture board "H" sit loosely on top of the slats. Add mattress.
4. If a trundle bed or drawer unit is to be added to this assembly it simply slides under the bed and does not attach to the bed.

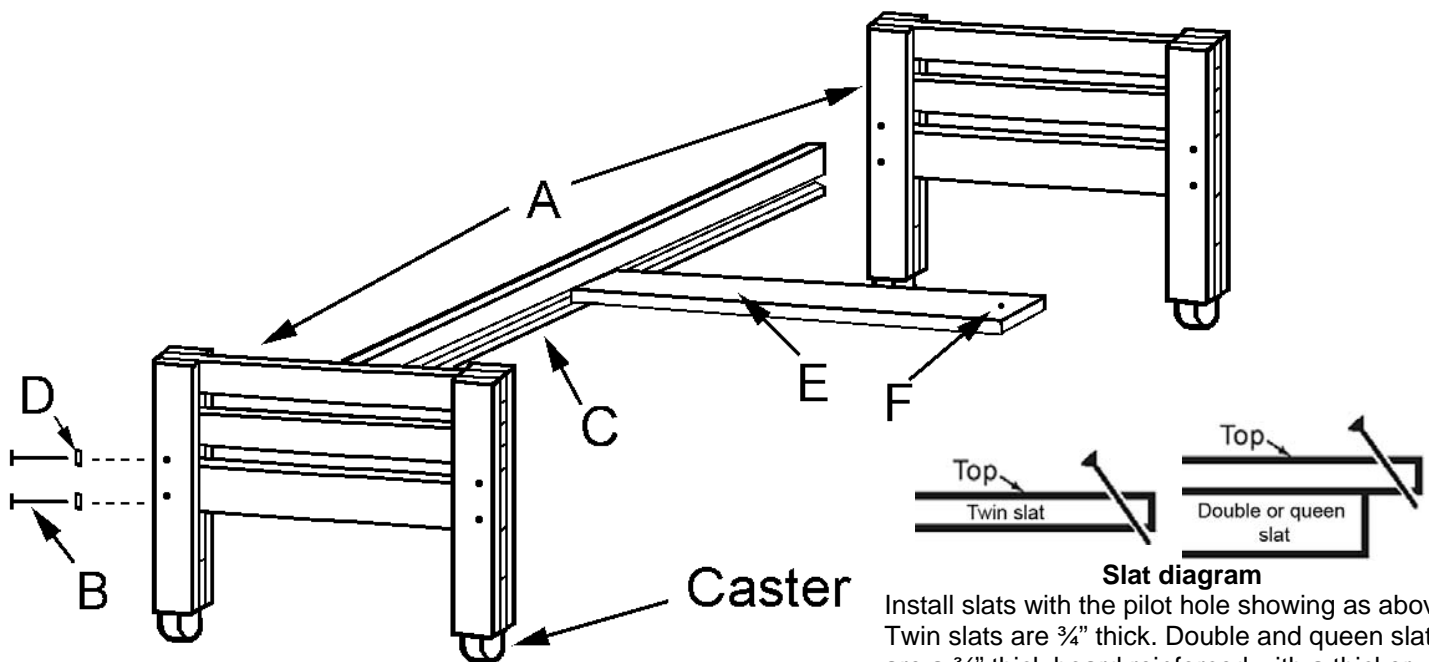

Slat diagram
Install slats with the pilot hole showing as above. Twin slats are $\frac{3}{4}$ " thick. Double and queen slats are a $\frac{3}{4}$ " thick board reinforced with a thicker board on the bottom – install as shown above.