



Junior Bunkbed Assembly Instructions

Please read the instructions completely prior to starting.

Tools required: $\frac{9}{16}$ " Socket or wrench
#2 Robertson or Phillips screwdriver

Contents:

- | | |
|-----------------------|---------------------------|
| A. 2 – Bed ends | F. 4 – 1 ½" Wood screws 4 |
| B. 8 – 5 ½" Lag bolts | G. 4 – 1 ¼" Wood screws |
| C. 2 – Side rails | H. 2 – Guard rails |
| D. 8 – Washers | I. Posture board |
| E. 4 – Slats | |

1. Fasten the 2 side rails "C" to the 2 bed ends "A" using 8 – 5 ½" lag bolts "B" with the 8 washers "D". Be sure grooves on side rails are on the inside, close to the bottom and the guard rail slots on the bed ends "A" are facing each other.
2. Slide 4 slats "E" into the side rails. 2 slats are placed ½" from the bed ends & secured with a wood screw "G" at each end of the slat. Position the other 2 slats evenly spaced between the end slats. Secure the centre slats with one 1 ½" wood screw "F" at each end of the slat.
3. Posture board "I" sits loosely on top of slats. Add mattress.
4. Slide 2 guard rails "H" into slots of top bed ends.

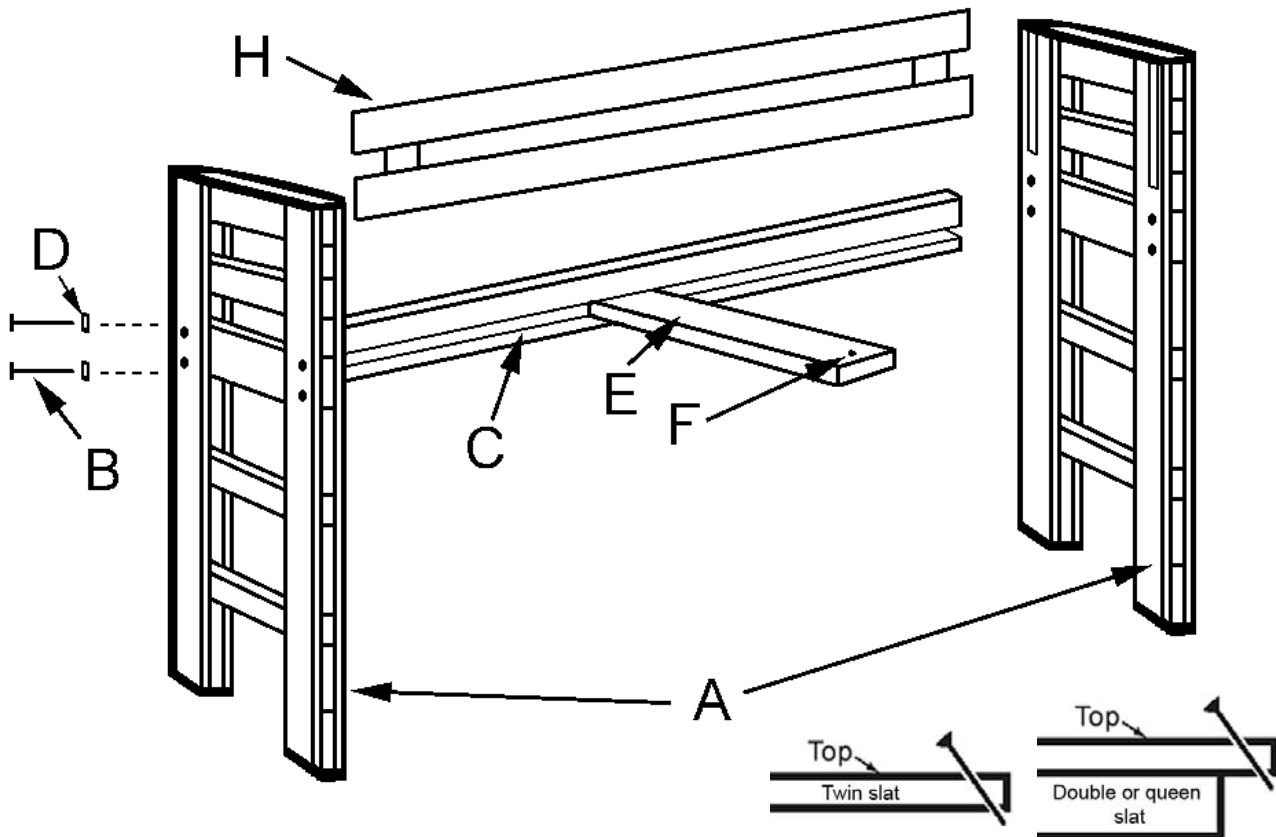

Slat diagram

Install slats with the pilot hole showing as above. Twin slats are $\frac{3}{4}$ " thick. Double and queen slats are a $\frac{3}{4}$ " thick board reinforced with a thicker board on the bottom – install as shown above.